



INDICATIVE PRODUCT IMAGE

Product file

Type	Compact
Mounting	Wall
Code	BEWS301LA30P11
Range	BEWS
Version	Saddle
Noise	32.8 dBA 10 m
Condensation	Air
Net weight	64 kg
PED	0
Defrost	Hot gas
Expansion	Valve
Application	LBP
Refrigerant	R290

Dimensions

Width L	671 mm
Depth P	975 mm
Height H	828 mm

Absorptions

Power consumption	940 W
Current consumption	5.1 A

Condenser

Fan-motors no.	1
Diameter	300 mm
Air flow	1200 m ³ /h

Unit cooler

Fan-motors no.	2
Diameter	200 mm
Air flow	1000 m ³ /h
Air throw	6.5 m

Compressor

Type	Hermetic
Compressors no.	1
Brand	EMBRACO
Voltage	230/1/50
Displacement	27.8 cm ³

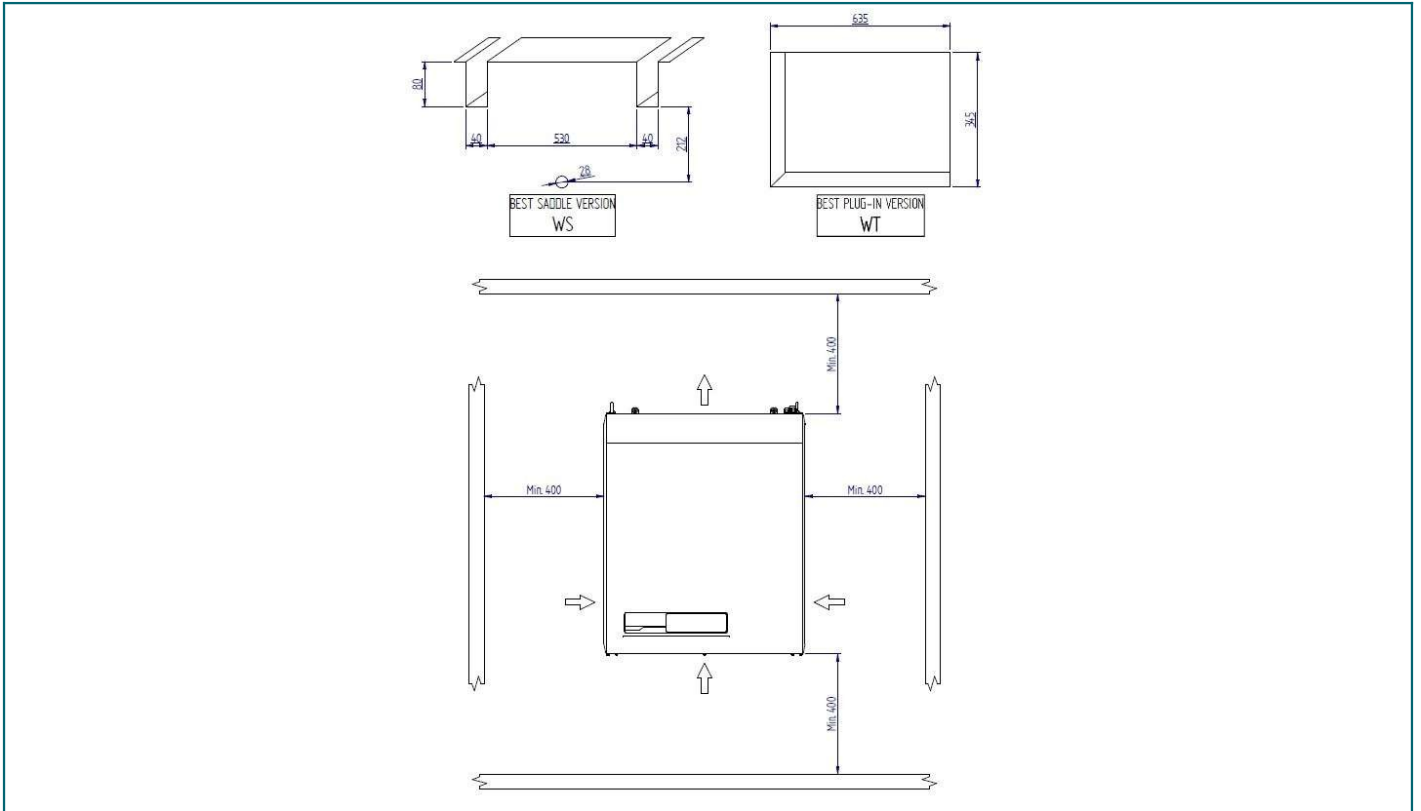

Refrigerating capacity table (W) - BEWS301LA30P11 - Refrigerant: R290

TA \ Cold room Temp	-25 °C	-20 °C	-15 °C
25 °C	956 (8.3 m³)	1144 (13.3 m³)	1349 (23.5 m³)
32 °C	892 (6 m³)	1069 (9.1 m³)	1263 (15.4 m³)
43 °C	774 (3.4 m³)	936 (5.1 m³)	1111 (7.6 m³)

Values referred to :

Suction gas : +20°C

Subcooling : 0K

Superheat : 100%

Compressor absorption :

Te -5°C (HBP); Tcond +50°C

Te -10°C (MBP); Tcond +50°C

Te -30°C (LBP); Tcond +50°C

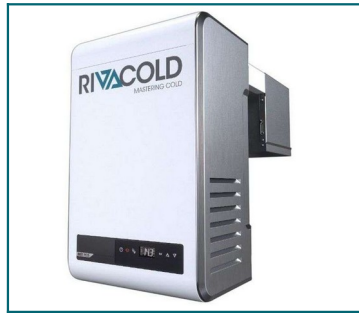

INDICATIVE PRODUCT IMAGE

MAIN COMPONENTS MECHANICAL PART

- Hermetic compressors with thermal motor protection
- Condenser with Ø5mm tubes with internale spiral rifling
- Evaporator with Ø5/16" tubes with internal spiral rifling
- Electronic fan-motors on both condenser and evaporator
- Mechanical thermostat valve supplied standard across entire range
- Hot gas defrosting
- Evaporating water tray
- R290 refrigerant charge ≤ 150g per circuit

CONTROL CIRCUIT and ELECTRIC PART

- Safety pressure switch on high pressure side
- High and low pressure probes
- Door micro wired with cable L= 2.5
- Door heater cable on LT models (L = 2.5m)
- LED cold room light with cable L= 5m
- Power cable L= 2.5 m with wired electrical plug
- Industrial Plug (2P+E or 3P+N+E) 16 A
- Industrial Plug (2P+E) 32 A only on BEWx352MA80P11 and BEWx352LA60P11

ELECTRONIC CONTROL

- Riv-olution: programmable electronic control with software developed by Rivacold
- Smart Defrost and Leak Detector functions
- Bluetooth connectivity
- APP to manage and control packaged system functions
- Connection cable for BMS (RTU Modbus Protocol) L=5 m
- LED display with new graphics and white backlight
- Backlit touch keyboard

STRUCTURE

- Self-supporting frame in galvanized metal sheet
- Easily removable housing to allow rapid access to the components in case of inspection or maintenance
- Installation kit complete with screws and washers to secure the packaged system to the wall of the coldroom and sealing putty in strips for insulation
- Plug-in thickness 100 mm for MT models and 150 mm for BT models (WT models)

OPTIONAL ITEMS

- Plug-in insulation kits supplied separately for saddle models (WS): 100mm, 150mm, 200mm
- Catephoresis treatment of exchangers (Condenser + Evaporator)
- Extension cable kits L=5m and L=10m (coldroom light cable, door heater cable, micro-switch cable)
- Remote control panel kits with 5m cable and 10m cable
- Presetting for Master & Slave (cable L=5m)
- Alarm cable kit L=5m
- IoT – Remote monitoring and control service (Wi-fi – 2G)