



INDICATIVE PRODUCT IMAGE

Product file

Type	Compact
Mounting	Ceiling
Code	BEC2301LA30P11
Range	BECM
Noise	35.3 dBA 10 m
Condensation	Air
Net weight	98 kg
PED	0
Defrost	Hot gas
Expansion	Valve
Application	LBP
Refrigerant	R290

Dimensions

Width L	930 mm
Depth P	1275 mm
Height H	440 mm

Absorptions

Power consumption	1030 W
Current consumption	5.6 A

Condenser

Fan-motors no.	2
Diameter	300 mm
Air flow	2540 m³/h

Unit cooler

Fan-motors no.	2
Diameter	300 mm
Air flow	1300 m³/h
Air throw	4.5 m

Compressor

Type	Hermetic
Compressors no.	1
Brand	EMBRACO
Voltage	230/1/50
Displacement	33.4 cm³

Technical data - BEC2301LA30P11

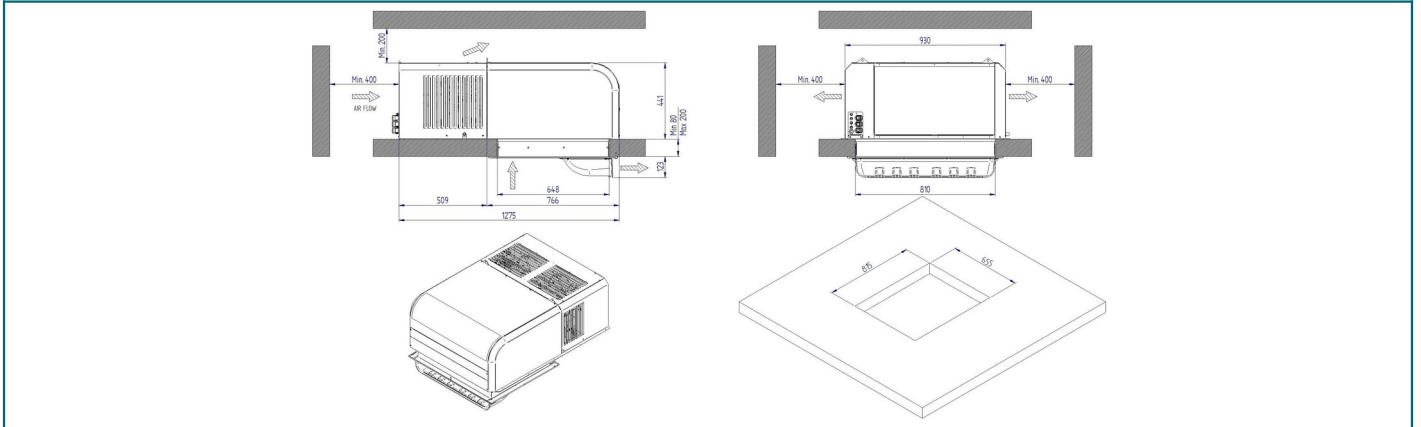

Refrigerating capacity table (W) - BEC2301LA30P11 - Refrigerant: R290

TA \ Cold room Temp	-25 °C	-20 °C	-15 °C	-10 °C
25 °C	1091 (10 m³)	1297 (17.3 m³)	1520 (28.2 m³)	1759 (46.6 m³)
32 °C	1017 (7.2 m³)	1212 (10.9 m³)	1422 (19.2 m³)	1645 (31.1 m³)
43 °C	891 (4.2 m³)	1067 (6.2 m³)	1256 (9.1 m³)	1455 (14.6 m³)

Values referred to :

Suction gas : +20°C

Subcooling : 0K

Superheat : 100%

Compressor absorption :

Te -5°C (HBP); Tcond +50°C

Te -10°C (MBP); Tcond +50°C

Te -30°C (LBP); Tcond +50°C



INDICATIVE PRODUCT IMAGE

MAIN COMPONENTS MECHANICAL PART

- Hermetic compressors with thermal motor protection
- Condenser with Ø5mm tubes with internal spiral rifling
- Evaporator with Ø5/16" tubes with internal spiral rifling
- Electronic fan-motors on both condenser and evaporator
- Mechanical thermostat valve supplied standard across entire range
- Hot gas defrosting
- Evaporating water tray
- R290 refrigerant charge ≤ 150g per circuit

CONTROL CIRCUIT and ELECTRIC PART

- Safety pressure switch on high pressure side
- High and low pressure probes
- Door micro wired with cable L= 2.5
- Door heater cable on LT models (L = 2.5m for 1x300 size and L=5.0m for 2x300 and 2x350 sizes)
- Remote control panel cable L=5.0 m
- LED cold room light with cable L= 5m
- Power cable L= 2.5 m with wired electrical plug
- Industrial Plug (2P+E or 3P+N+E) 16 A
- Industrial Plug (2P+E) 32 A only on BEWx352MA80P11 and BEWx352LA60P11

ELECTRONIC CONTROL

- Riv-olution: programmable electronic control with software developed by Rivacold
- Smart Defrost and Leak Detector functions
- Bluetooth connectivity
- APP to manage and control packaged system functions
- Connection cable for BMS (RTU Modbus Protocol) L=5 m
- LED display with new graphics and white backlight
- Backlit touch keyboard

STRUCTURE

- Epoxy powder finish on all metal sheets
- Self-supporting frame in galvanized metal sheet provided with lateral bends for the fixing of the unit to the ceiling of the cold room so as to make the installation easier and improve the insulation
- Easily removable housing to allow rapid access to the components in case of inspection or maintenance
- Installation kit complete with screws and washers to secure the packaged system to the wall of the coldroom and a roll of insulating sponge to be applied on the perimeter of the cold room hole
- The machine consists of two parts, the cooling unit to be installed on the roof top of the cold room and a part of the telescopic air duct to be fixed inside in order to limit the footprint inside the cold room, make installation easier and insulation more efficient.
- The installation of BEST CM is possible on coldroom with panel thickness from 80mm to 200mm.
- The smaller models (1x300) are supplied with a panel that finish the evaporator side to be fitted internally on the ceiling level, with no additional encumbrance inside the cold room.
- The models of the larger sizes (2x300 and 2X350) are supplied with a conveyor that increases the air throw and ensures greater temperature uniformity inside the cold room

OPTIONAL ITEMS

- Air conveyor for 1x300 size models
- Catephoresis treatment of exchangers (Condenser + Evaporator)
- Extension cable kits L=5m and L=10m (coldroom light cable, door heater cable, micro-switch cable)
- Presetting for Master & Slave (cable L=5m)
- Alarm cable kit L=5m
- IoT – Remote monitoring and control service (Wi-fi – 2G)